



Low Profile Antenna Heavy Duty, Narrow Band, HF

HDLP-NB-HF

PARTS LIST

The package includes an antenna, and a matching network (1).

PLACEMENT

Choose a spot in the center of the ground plane. The antenna should be mounted, as near the center as possible, however, a clear location is also required. Before drilling any holes verify the area under the ground plane is clear of obstructions that would interfere with mounting the hardware for the antenna.

MOUNTING

1. Use the antenna to mark six (6) screw holes and one (1) connector hole on the vehicle.
2. Punch or drill connector hole 3/4" minimum diameter.
3. Drill six (6) mounting holes (3/8 diameter drill) to accept #14 X 1" sheet metal screws.
Note: *You may also use footprint template (Included on following page), to pre-drill holes.*
4. Mount the antenna.
Note: *The front footprint, on left side of diagram, should be attached first to protect the tuning assembly.*
5. Route the coaxial cable appropriately.
Note: *actual sealer used depends on environment. Dow Corning Silastic 732 RTV or equivalent is recommended (not supplied with antenna).*
6. Attach matching network to antenna base and connect the feedline to the network female connector.
7. Attach feedline cable to antenna and radio. This completes installation.

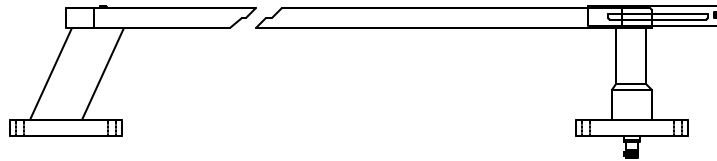



TUNING PROCEDURE

1. Set the center operating frequency by connecting an SWR meter directly to the base of the antenna.
2. Tune antenna to desired frequency by loosening the screws on the side of the tuning brackets.
3. Mark the final location of the tuning assembly.
4. Apply thread lock to the screws and secure the tuning assembly in place.
5. Reattach the matching network to the base of the antenna, and connect the feedline.

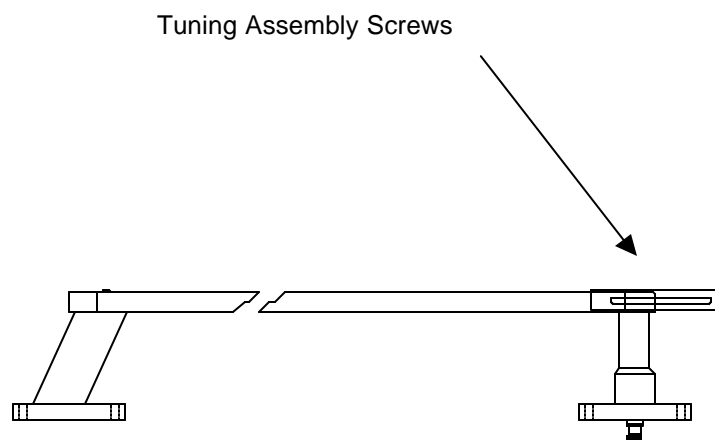



Note: The 0.750 diameter hole is for the connector and is only required at the rear feed location. The other three holes are for mounting bolts and are identical for each foot.

