



Installation Considerations Magnet Mount, Narrowband, VHF Antenna

CMAG-NB-VHFL (FOR USE WITH SUV AND VANS ONLY)

VERIFY:

1. **Part List:** The package includes an antenna that is attached to cable and connector for your two way-radio. Use only the components supplied with the antenna.
2. **Bandwidth:** VHF Narrowband antennas are 12 MHz wide and are designed to operate between 150 MHz to 162 MHz unless otherwise specified. Be certain that the antenna was tuned to the frequency required.

INSTALLATION:

1. **Placement:** Select a flat surface on the rear of the roof as shown below. Antenna is design to operate best placed in the corner of the roof with the approximate dimensions shown.

Note: If the area is convex, a rocking motion will be encountered. A concave surface will reduce the magnet's holding power affecting the quality of the antennas "RF" ground.

Keep in mind that some vehicles will have aluminum or composite roofs.

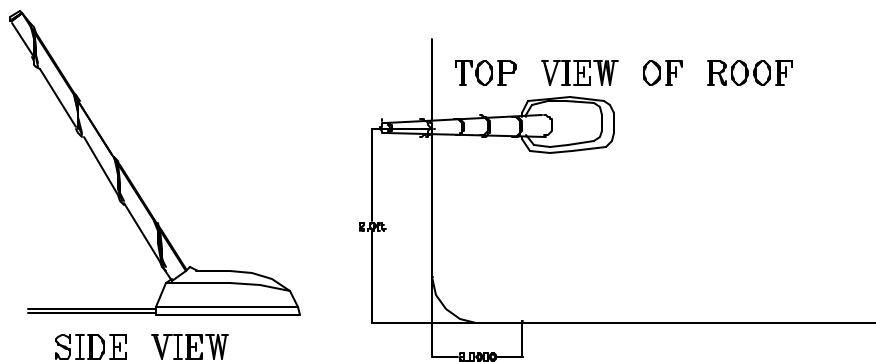

2. **Run Cable:** Route coaxial cable toward the two-way radio by passing the cable through the rear door the being tucked under the interior vehicle trim. Cable will normally not be damaged by opening and closing the rear door.

Note: Be careful not to tear the sheath of cable when pulling through sharp body panels. If a hole appears in the cable's sheath, cover with several layers of a high quality electrical tape.



3. **Electromagnetic interference:** Do not coil feedline cable or matching network. If limited space is a concern, fold the cable upon itself rather than coiling. Do not tape or secure any feedlines to data or vehicle cables during installation.
4. **Cable Cutting:** If desired, cut the feedline cable to the length required to reach the transmitter.

Note: *The feedline may be cut only between the last cable junction and transmitter (Refer to the VHF Cellular Look-Alike Antenna Cabling Diagram drawing).*

TESTING:

Installation testing must take place at the transmitter side of the feedline. Make sure all doors, the hood, and trunk are closed.

Note: *Some vehicles are sensitive to VHF frequencies. STI-CO suggests that you isolate feedlines and check for unwanted interference with the ignition switch on.*

1. **Reflective Power:** A measurement of reflective power using a wattmeter, you can expect up to 11% reflected power. When results are greater than 11%, reposition antenna.
2. **SWR:** A measurement of SWR (standing wave ratio) will yield better than 2:1. If greater than 2:1, reposition antenna.
3. **Continuity:** A test of continuity between the center pin and ground will show as a short for this antenna.

CAUTION: *The mast must be removed at knurled section before entering a car wash.*