

# Superband ®, UHF Antenna

## RDCA-SB-UHF

### VERIFY:

1. **Part List:** The system package includes magnetic base, spring assembly, mast, matching cable network, feedline, and connectors if applicable. Use only components supplied with the antenna system (Refer to Figure 1-Parts List).
2. **Bandwidth:** UHF Superband ® antennas are 106 MHz wide. The antenna is designed to operate between 406 MHz to 512 MHz unless otherwise specified.

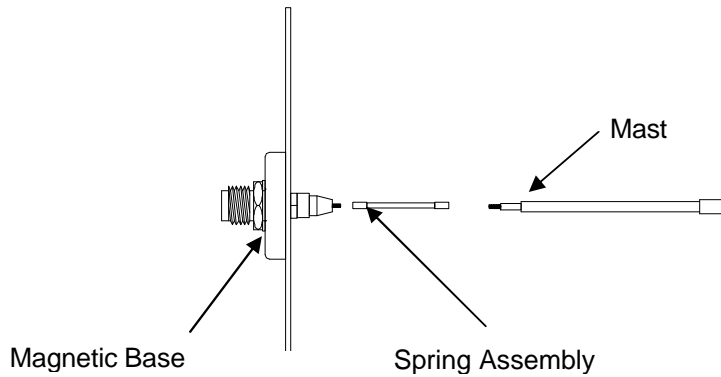

Figure 1  
Parts List

### BASE INSTALLATION:

This antenna is designed with a universal mounting system HOWEVER due to the amount of differences between vehicle platforms we can't anticipate all of the challenges an installer may face. A certain amount of modification may be needed based on your particular installation.

The installation begins by locating a point on centerline of the back deck that is clear of any obstructions such as rear brake lights or safety belt restraint latches. The antenna base should be at least 6 to 8 inches from the rear glass. See note A in figure 2 below.

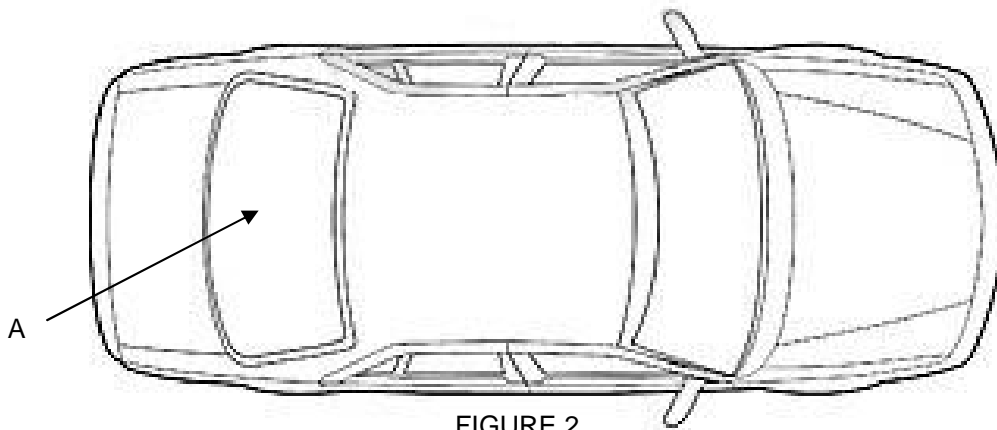

FIGURE 2

1. Drill a 7/16" hole from the underside of the deck through the metal frame as close to the chosen location as possible. Be careful not to go through the insulation in order to better conceal the base of the antenna.

Using a sharp knife cut a small slit or X over the top of the drilled hole to allow the top of the base to protrude.

2. Install the magnetic antenna base from the underside of the deck. See figure 3 below.

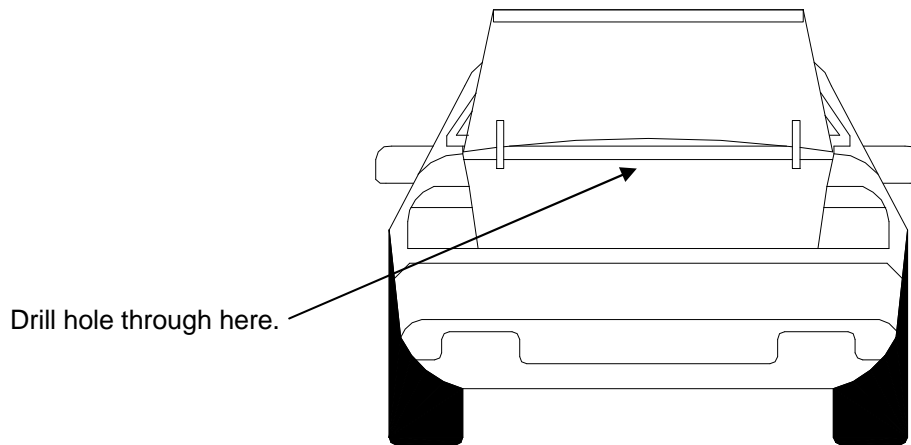

Figure 3

3. The magnet is designed to hold the base in place while 2 sheet metal screws are installed as close to the magnet as possible to secure the assembly to the frame. See figure 4 below.

\* Caution: Cabling must have strain relief support to prevent damage to connector.

Install 2 sheet metal screws  
as close to magnet as  
possible.

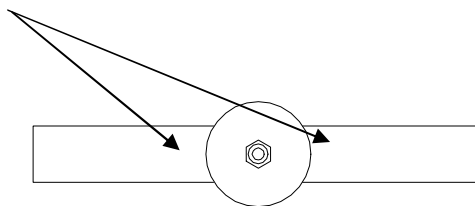

Figure 4

4. From the top of the deck carefully thread the spring assembly onto the protruding base. Screw the mast onto the spring assembly.

**NOTE** It is very important that the metal portion of the antenna is kept at least 1 inch away from any vehicle chassis ground points including vehicle frame, defogger wires, factory OEM in glass wires, trim screws etc. **NOTE:** Vehicles with aftermarket tint must have non-metallic tint.



## TESTING AND VERIFICATION:

Installation testing, if required, must take place at the transmitter side of the feedline. This will ensure that the cable connectors and cables have the proper continuity. Make sure all doors, hood, and trunk are closed.

**Note:** *Some vehicles are sensitive to UHF frequencies. STI-CO suggests that you isolate feedline and check for unwanted interference with the ignition switch on.*

1. **Reflective Power:** A measurement of reflective power using a wattmeter, you can expect up to 11% reflected power. When results are greater than 11%, recheck grounding.
2. **SWR:** A measurement of SWR (standing wave ratio) will yield better than 2:1. If greater than 2:1, recheck grounding.
3. Connect the feedline provided from the antenna base to a wattmeter. Connect from the wattmeter to the transmit radio. Set the radio to a frequency that is closest to the center of the band of operation. Measure the reflected power
4. Check the reflected power above and below the center frequency to verify antenna matching. Remove wattmeter and proceed to the final hook-up.
5. Connect the matching harness from the antenna base to the radio.
6. Installation is now complete.